

LIETDOS-BIO ASSESSMENT APPROACH TO THE ENVIRONMENT NON-HUMAN BIOTA EXPOSURE BY IONIZING RADIATION

T. Nedveckaitė^a, V. Filistovic^a, D. Marčiulionienė^b, N. Prokoptchuk^a, A. Gudelis^a,
R. Plukienė^a, V. Remeikis^a, and J. Vives i Batlle^c

^a *Institute of Physics, Savanorių 231, LT-02300 Vilnius, Lithuania*

E-mail: tatjana@cablenet.lt

^b *Institute of Botany of Nature Research Centre, Žaliųjų ežerų 49, LT-08406, Vilnius, Lithuania*

^c *Westlake Scientific Consulting Ltd, The Princess Royal Building, Westlakes Science and Technology Park, Moor Row, Cumbria CA24 3LN, United Kingdom*

Received 14 January 2010; revised 24 February 2010; accepted 19 March 2010

The increasing public concern over environmental hazards has led to the emergence of a variety of national and international legal commitments for the environment protection. The LIETDOS-BIO assessment approach to Environment protection from ionizing radiation is being developed to address contamination issues associated with nuclear power production and radioactive waste disposal in Lithuania. The LIETDOS-BIO was designed to be consistent with MCNPX code and Crystal Ball software for uncertainty analysis. The modelling of radionuclide migration through the components of a hypothetical waste disposal system (hypothetical Stabatiškės waste disposal contaminated zone, unsaturated zone, aquifer, and recharge to Lake Drūkšiai) has been performed using the computer code RESRAD-OFFSITE and a number of site-specific parameters together with distributions. Submerged hydrophytes were selected as biota exposure indicators because they represent the largest biomass in Lake Drūkšiai and have comparatively high radionuclide activity concentrations. The presented data demonstrate that submerged hydrophyte exposure is determined mainly by natural background radionuclides with predominance of ²²⁶Ra ionizing radiation in the case of external exposure and internally incorporated α -emitters. ²³⁸U is the major contributor in the case of internal exposure. The LIETDOS-BIO code for non-human biota dose rate calculations was assessed during IAEA EMRAS BWG scientific program performance, and modelled-to-measured activity concentration predictions were found to be acceptable with the absolute value of Z-score between 0 and 2 derived from the Z-score intercomparison. The preliminary data presented here make it possible to investigate the relevance of Lake Drūkšiai as a cooling pond for the progression of nuclear energetics in Lithuania. A final decision on acceptability of this option awaits further review.

Keywords: environmental radiation protection, non-human biota, LIETDOS-BIO approach

PACS: 28.52.Nh, 28.41.Kw, 87.55.N-

1. Introduction

Ionizing radiation is ubiquitous. A wide variety of plants and animals as ecological receptors, generically referred to as “non-human biota”, are and always have been, exposed to naturally occurring radiation. In addition, human activities have enhanced the levels of radiation and radioactivity both globally through fallout from above-ground testing of nuclear weapons and locally through release of radioactivity from the nuclear fuel cycle activities from uranium mining through nuclear power generation to waste disposal.

Over the past years, numerous investigations were carried out to study the potential effects of ionizing radiation using different assumptions and reference radiation dose rates. The latter serve as benchmarks for

assessing potential risks to populations of non-human biota from exposure to ionizing radiation [1, 2]. The increasing public concern over environmental hazards has led to the emergence of a variety of national and international legal commitments for protection of the environment. These commitments demonstrate a generally held view that an explicit means of demonstrating protection of biota and ecosystems from harmful effects of ionizing radiation is also needed, and may often be legally required [3].

The Ignalina Nuclear Power Plant (INPP) two units of Chernobyl NPP type reactors were commissioned in December 1983 and August 1987, respectively. After closure of INPP on 31 December 2009, the additional waste from decommissioning will need to be handled in compliance with the new requirements and rules of

the Republic of Lithuania as well as up-to-date International Atomic Energy Agency (IAEA) and European standards governing solid radioactive waste management [4].

The *Joint Convention on the Safety of Spent Nuclear Fuel Management and on the Safety of Radioactive Waste Management* is a body set-up with the cooperation of the IAEA in order to protect individuals, society, and the environment against the harmful effects of radiation, and includes the following statement: “Each Contracting Party shall take appropriate steps to ensure that at all stages of spent fuel management (radioactive waste management), individuals, society and the environment are adequately protected against radiological hazards” [5]. The resolution to implement this convention was adopted in 1997 and came into force in June 2001. The convention requires the development and testing of an integrated approach whereby decision-making can be guided by sound scientific judgments. To put assessment of nuclear sites into context, a comparison of biota exposure due to discharged anthropogenic radionuclides with that of background radiation is required. The LIETDOS-BIO assessment approach to Environment protection from ionizing radiation (the part of LIETDOS software package) is being developed to address contamination issues associated with nuclear energy production and radioactive waste disposal and repositories in Lithuania.

2. Methodology: description of procedures, equations, and parameters used in the model

Based on knowledge of radionuclide distribution within the environment, a simplified compartmentalization of the ecosystems was used as a basis for selecting suitable target geometries (phantoms) for the dose rate calculations. The LIETDOS-BIO model and calculation tools for the biota exposure evaluation were composed under the following main assumptions:

- Each organism is represented as a simple geometry such as an ellipsoid or cylinder so that the fraction of decay energy emitted within the organism can be calculated.
- Reference organism approach [6, 7] involves the use of a limited number of different types of animals and plants. Selection of reference organisms is based on their radioecological significance and radiosensitivity, and endpoints of importance (e. g. morbidity, mortality, reproductive capacity, mutation rate).

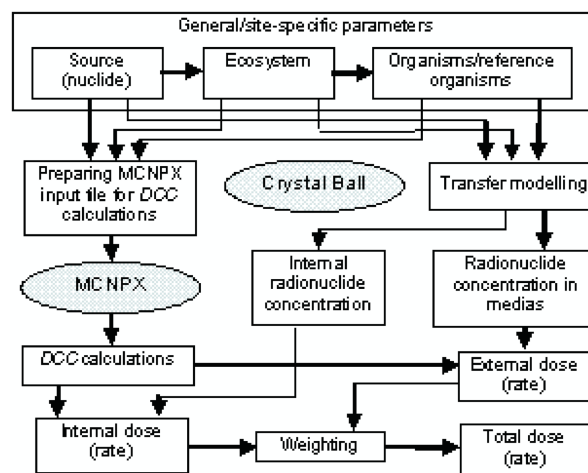

Fig. 1. LIETDOS-BIO modular structure.

- The earlier obtained data (such as standard dimensions and density of the reference organism) are used to evaluate physically a Dose Conversion Coefficient (*DCC*) for each radionuclide.
- The average dose throughout the volume of the organism is calculated, for both internal and external contamination.
- Assessment of the dose to each organism is carried out using concentration factors (internal dose) and positioning relative to soil/sediment or water (external dose).

Various data are required to enable dose calculations:

- Concentrations of each radionuclide in the soil/sediment, water, and air.
- Concentration factors for each radionuclide in each organism to be assessed relative to soil, water, or air.
- Organism dimensions.
- The proportion of time the organism spends in different “compartments” of the ecosystem.

The LIETDOS-BIO code was designed to be consistent with MCNPX (general purpose Monte Carlo radiation transport code that can be used for neutron, photon, electron, or coupled neutron/photon/electron transport) [8] as well as the Crystal Ball add-on software for uncertainty analysis, which is capable of performing Monte Carlo simulations in Excel spreadsheets [9]. LIETDOS-BIO is run in combination (Fig. 1) with compartmental model using differential equations and transfer factors to simulate the transport of radionuclides through ecosystems to biota.

At all stages through its development, this methodology deals with deeper levels of uncertainty and it is

acknowledged that uncertainty is intrinsic to complex systems. The basic dosimetric methods are reasonably well defined, but it is generally accepted that prediction of the uptake of radionuclides from the surrounding environmental media by organisms is a major source of uncertainty [10]. Additionally these methodologies cannot assess reliably situations in which the assumption of equilibrium is invalid [11]. As a result uncertainty analyses are of paramount importance.

2.1. Preparing MCNPX input file for calculation of dose conversion coefficients (DCC)

The MCNPX code is widely used for radiation transport simulation with relatively high flexibility and is now applied to many fields including the radiation safety management, health physics, medical physics, and reactor design [10]. Based on information about the organism geometry specification, description of materials, specification of the particle source, and the type of answers desired (energy deposited in a given volume) LIETDOS-BIO automatically generates an input file (specific to LIETDOS-BIO) which is subsequently read by the MCNPX code in order to calculate *DCC* (see equations below) for non-human biota. An example of geometry specification for external exposure *DCC* calculation by MCNPX is presented in Fig. 2. Dose conversion coefficients have been computed using the ICRP database [12] for radionuclide transformations, energy and intensity of emissions and the MCNPX code. The user supplies information required by the code such as the geometry and physical characteristics (e. g. density) of the environment and biota which are to be simulated and the source distribution of the radiation. As the output we used energy deposition averaged over a biota cell – (tally 6 of MCNPX code [MeV/g]).

2.2. Method used for deriving uncertainty and accuracy estimates

Like any complex environmental problem, the evaluation of the ionizing radiation impact is inconvenienced by uncertainty. In radioecology, stochastic calculations are used to an increasing extent. At all stages, from the problem formulation up to the exposure evaluation, the assessments depend on models, scenarios, assumptions, and extrapolations as well as technical uncertainties related to the data used. Uncertainties can be categorized as follows:

- Knowledge uncertainties defined as a lack of scientific knowledge about parameters and factors or

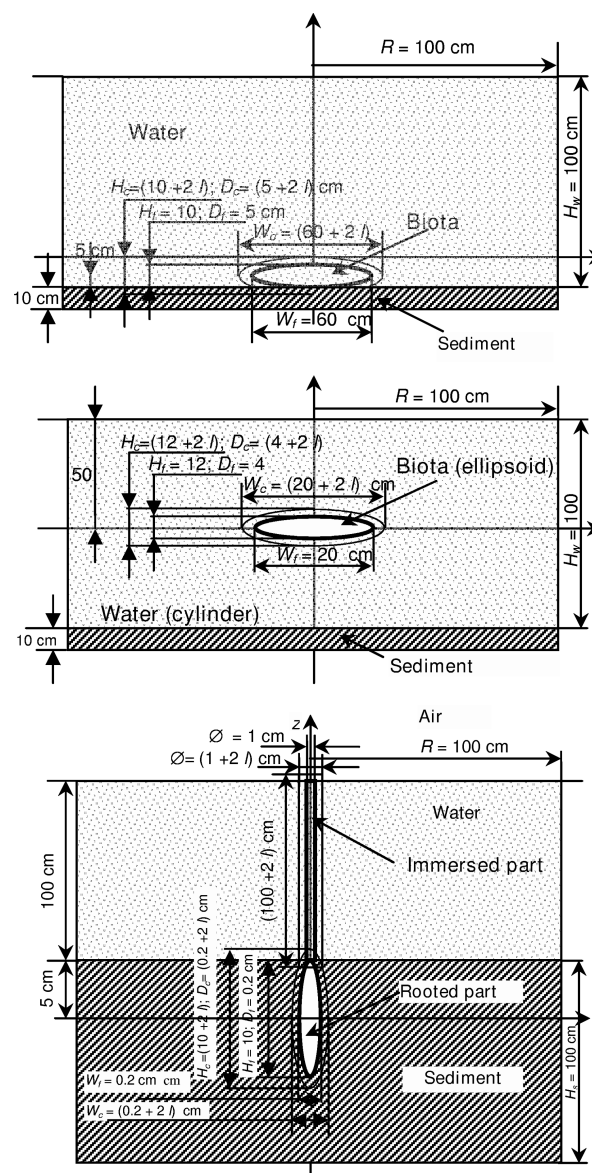

Fig. 2. Geometry specifications for external exposure of *DCC* calculations by means of MCNPX code: organism on the bottom of water layer, organism in the middle of water layer, and rooted submerged hydrophytes.

models. It includes measurement errors as well as model misrepresentation and can be reduced through further study. It may be possible to represent some of these uncertainties by probability distributions.

- Variability is defined as a natural variability due to changes in a data set. Variability is easier to represent quantifiably through simple standard deviation or a frequency distribution or through probability density function.

More recent work has been focused on other aspects of uncertainty – particularly related to using uncertain

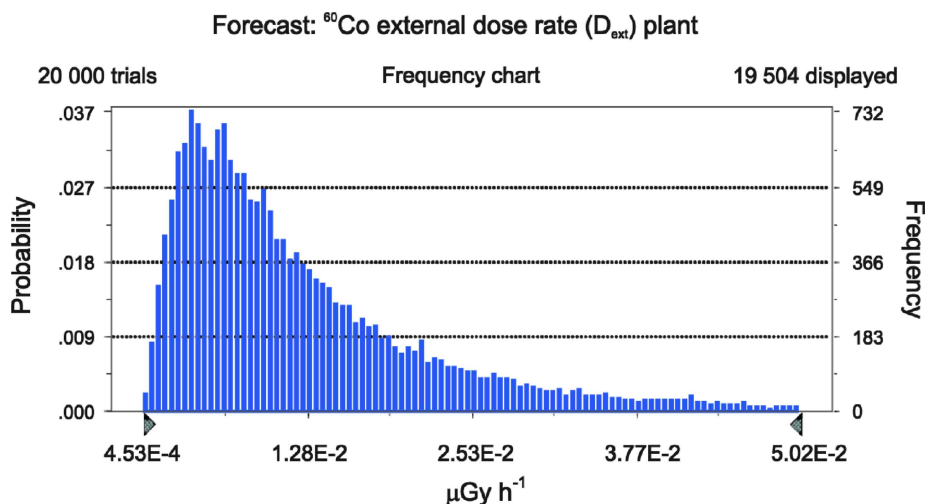

Fig. 3. Lake Drūkšiai macrophytes external dose rate simulation as a result of ^{60}Co ionizing radiation and Crystal Ball statistical techniques with 20 000 number of trials and Latin Hypercube sampling.

information in decision-making in a radiation protection context, taking into account the following sub-categories:

- Numerical uncertainties for calculation of the dose rates (distribution coefficients, the concentration ratios, occupancy factors, etc.) and in the input data (concentrations in soil, water, sediments, etc.).
- Model and scenario uncertainties arising from the mathematical representation of the conceptual models and the imprecision in the numerical method used to solve the mathematical model.
- Conceptual errors in the model design such as not considering all the relevant biological (ecological) environmental processes (oversimplification) or including too many processes (overparametrization), resulting in both cases in an unreliable modelisation of the situation that the model is trying to represent.

To estimate the uncertainty of the endpoints of the exposure assessment, uncertainties in the inputs and parameters must be propagated through the model using Monte Carlo analysis. Point estimates in a model equation are replaced with probability distributions, samples are randomly taken from each distribution, and the results are combined, usually in the form of a probability density function in order to obtain a confidence interval. The uncertainties in the LIETDOS-BIO model have been determined by using the Crystal Ball code statistical technique with 20 000 number of trials and the Latin Hypercube sampling method. An example of the external dose rate evaluation is presented in Fig. 3. The sensitivity analysis is used to identify the relative quantitative contribution of uncertainty associated with

each input and the parameter value to the endpoint of concern.

2.3. Biota internal and external exposure by ionizing radiation: dose rate estimation

Internal dose rates were calculated as the product of media concentration C_{water} (e. g., Bq/l), concentration factors CR (e. g., Bq/kg biota, fresh weight (FW) per Bq/kg sediment, dry weight (DW)), and dose conversion factors DCC_{int} (Gy/h per Bq/kg). Thus, the internal dose rate $\dot{D}_{\text{internal}}$ and the biota activity concentration C_{biota} were calculated as follows:

$$\dot{D}_{\text{internal}} = DCC_{\text{int}} \cdot C_{\text{biota}} \quad (1)$$

In the case of freshwater ecosystem

$$C_{\text{biota}} = CR \cdot C_{\text{water}} = CR \cdot \frac{C_{\text{sediment}}}{K_d}, \quad (2)$$

where C_{sediment} is the activity concentration of sediments (Bq/kg, dry weight) and K_d is the partitioning coefficient (Bq/kg sediment DW per Bq/L water).

In the case of terrestrial ecosystem

$$C_{\text{biota}} = CR \cdot C_{\text{soil}}, \quad (3)$$

where CR is the concentration factor in units of Bq/kg biota (FW) per Bq/kg soil (DW); C_{soil} is the activity concentration of soil (Bq/kg DW).

Estimates of the contribution to dose from internal sources of the radioactive material were made assuming that not all of the decay energy is retained in the organism tissue. Dose modifying factors (otherwise known as radiation weighting factors) may be included (i. e., $w_R = 1$ for electrons and photons, and $w_R = 20$ for

alpha particles) to calculate the weighted internal dose rate. The progeny of chain-decaying radionuclides were also included, and the radionuclides were presumed to be homogeneously distributed in the tissue of the receptor organism. Based on these assumptions it was possible to derive dose conversion factors DCC_{int} for unit concentrations of a nuclide in the tissue of an organism (Gy/d per Bq/kg).

External dose rate estimations from external sources of radioactive material were performed assuming that not all of the ionizing radiation was deposited in the organism (i. e., pass-through and self-shielding). This is a non-conservative assumption, tantamount to assuming that the radiosensitive tissues of concern (the reproductive tissues) are on the surface of a very small organism.

Estimates of the contribution to the dose rate from the external sources of radioactive material were made assuming that the source medium (water, sediments, or soil) is not infinite in extent and contains a uniform concentration of radionuclides. These assumptions result in reasonably realistic estimates of dose rates for radionuclides which are dispersed in the source medium, because the range of electrons emitted in radioactive decay is no more than a few cm and the mean-free-path of emitted photons is no more than a few tens of centimetres.

The external dose rate in fresh weight sediments in the case of freshwater ecosystem can be evaluated as follows:

$$\begin{aligned} \dot{D}_{\text{ext, sed}} &= DCC_{\text{sed}} \cdot C_{\text{sed, wet}} \\ &= DCC_{\text{sed}} \cdot C_{\text{sed, dry}} \cdot \frac{\rho_{\text{sed, dry}}}{\rho_{\text{sed, wet}}}, \end{aligned} \quad (4)$$

where DCC_{sed} is the external dose conversion coefficient (Gy/d per Bq/kg sediment FW); $C_{\text{sed, wet}}$, $C_{\text{sed, dry}}$ are activity concentrations of fresh (Bq/kg FW) or dry (Bq/kg DW) sediments, respectively; $\rho_{\text{sed, wet}}$, $\rho_{\text{sed, dry}}$ are the wet and dry sediment densities (kg/l).

The external dose rate from water (Gy/d)

$$\begin{aligned} \dot{D}_{\text{ext, wat}} &= DCC_{\text{sed}} \cdot C_{\text{wat}} \\ &= DCC_{\text{sed}} \cdot \frac{1}{K_d} C_{\text{sed, dry}}, \end{aligned} \quad (5)$$

where DCC_{sed} is the external dose conversion coefficient (Gy/d per Bq/l water).

The exposed organism is assumed to be a finite-sized organism. This assumption does not result in overestimation of external dose rates for any finite-sized organism, because it factorizes attenuation of photons and electrons during their transport through the organism.

Therefore, not all of the energy emitted by radionuclides in a uniformly contaminated and finite source medium is absorbed uniformly throughout the medium; the dose rate in the organism is essentially not the same as the dose rate in the medium itself.

2.4. LIETDOS-BIO libraries and databases

LIETDOS-BIO contains a nuclide library (based on ICRP 38 [12]), organisms/reference organisms' parameters library (terrestrial and freshwater ecosystems), and a partitioning coefficients library. LIETDOS-BIO contains the following concentration ratio (CR) databases: site-specific stable nuclide (when available) and radionuclide CR values as presented elsewhere [13–17].

It is shown [18] that transfer coefficients which are defined as concentration ratios are not suited for stochastic calculations. It has been determined that the probability density of concentration ratios follows a log-normal distribution. An example of site-specific CR evaluation based on ^{90}Sr investigation in the Lithuanian freshwater ecosystem is presented in Fig. 4(a). Regularities of macrophyte functioning and their role in migration of ^{90}Sr were established in ten Lithuanian lakes and in the Ignalina NPP cooling pond. 19 species of macrophyte forming a greatest phytomass in water were investigated. The presence of stable Sr and Ca, as well as many biological and physical processes play the main role in determining ^{90}Sr concentration levels of the investigated species. The frequency of ^{90}Sr CR distribution based on the evaluation of 250 samples of 19 macrophyte species in Lithuanian lakes is presented in Fig. 4(b).

3. Results and discussion

This investigation presents the comparison of two LIETDOS-BIO assessments: (a) Lake Drūkšiai submerged hydrophyte exposures to natural background radionuclides, and (b) exposures at an INPP and hypothetical low-level near-surface radioactive waste disposal in the vicinity of lake with anthropogenic radionuclides discharged to Lake Drūkšiai. After closure of INPP on 31 December 2009 additional decommissioning waste is planned, compliant with the new requirements and rules of the Republic of Lithuania as well as up-to-date IAEA and European standards governing solid radioactive waste management. The hypothetical very low-level near-surface radioactive waste disposal facility is

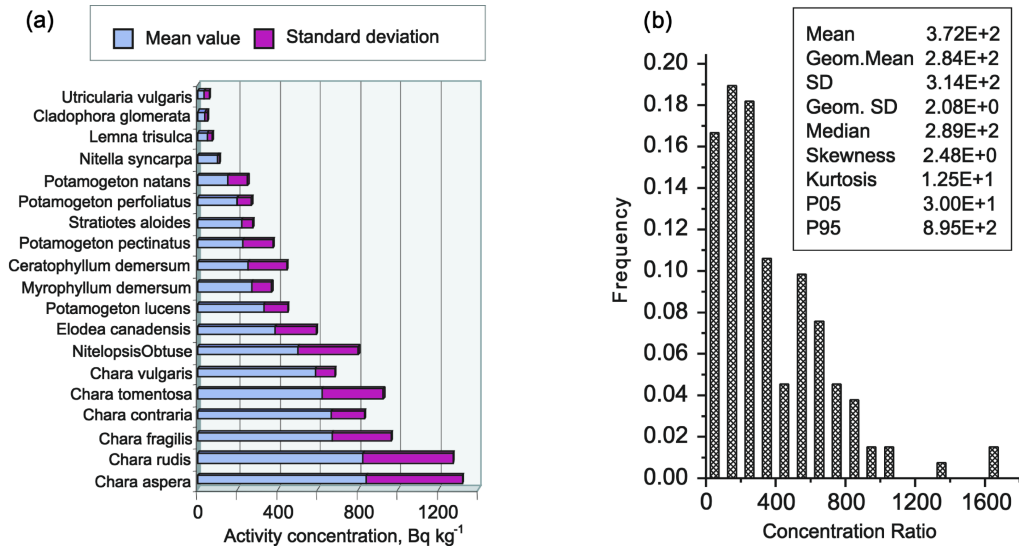

Fig. 4. (a) Site-specific values of ^{90}Sr activity concentrations for different types of freshwater ecosystem macrophytes and (b) distribution of corresponding concentration ratios values [17].



Fig. 5. Ignalina NPP and hypothetical low-level near-surface radioactive waste disposal situated near Lake Drūkšiai.

depicted in Fig. 5. The distance to Lake Drūkšiai is about 1.5 km.

The existing INPP Environment Monitoring Programme [13, 14] includes the monitoring of all the environmental exposure pathways that may cause impacts on biota. LIETDOS-BIO simulated distributions of discharged anthropogenic and natural background radionuclide concentrations in bottom sediments are presented in [19]. The modelling of radionuclide migration through the components of the waste disposal system (waste disposal – contaminated zone, unsaturated zone, aquifer – recharge to Lake Drūkšiai) has been performed using the computer code RESRAD-OFFSITE [20]. The transport of radionuclides due to diffusion-advection with respect to hydrodynamic dispersion is estimated considering the decay of parent radionuclide, the ingrowths of progeny radionuclide, and radioactive decay. RESRAD-OFFSITE uses a number of parameters together with distribution values to improve the

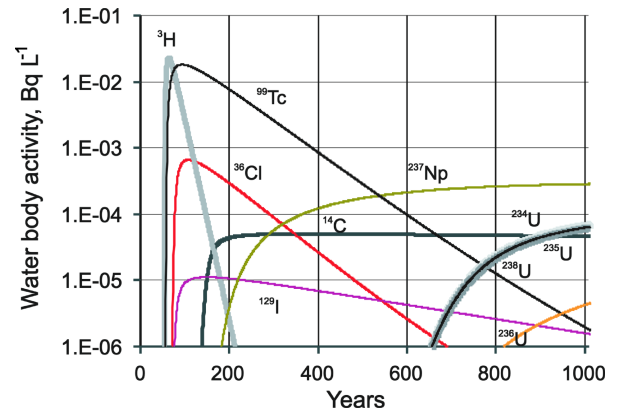

Fig. 6. Time dependent Lake Drūkšiai water activity according to hypothetical low-level near-surface radioactive waste disposal acceptance criteria.

accuracy of the calculations. The level in the characterization of the parameter uncertainty depends on the site-specific available data. Site-specific physical, hydrological, geochemical, and meteorological data [13–17] have been applied. The time dependent RESRAD-OFFSITE code simulated hypothetical Lake Drūkšiai water activity is presented in Fig. 6.

Submerged hydrophytes were selected as biota exposure indicators because they represent the largest biomass in this lake and have comparatively high radionuclide activity concentrations. Previous natural radionuclide measurements were used to compare the exposure of submerged hydrophytes due to anthropogenic radionuclides released by INPP and hypothetical waste disposal with that of the natural background radionuclides in the LIETDOS-BIO simulation [17, 19]. A special emphasis was given to ^{238}U and ^{232}Th sediment

Table 1. Estimated weighted dose rates to submerged hydrophytes attributed to natural background radionuclides.

Parameters	Dose rate, $\mu\text{Gy/h}$					
	^{40}K	$^{210}\text{Pb}^*$	$^{210}\text{Po}^*$	^{238}U	$^{226}\text{Ra}^{**}$	^{232}Th
Internal dose rate						
Mean	$4.3 \cdot 10^{-3}$	$1.0 \cdot 10^{-3}$	$3.1 \cdot 10^{-1}$	0.8	$1.3 \cdot 10^{-1}$	$2.9 \cdot 10^{-2}$
Median	$3.6 \cdot 10^{-3}$	$0.8 \cdot 10^{-3}$	$2.9 \cdot 10^{-1}$	0.4	$1.0 \cdot 10^{-1}$	$2.2 \cdot 10^{-2}$
Standard deviation	$3.0 \cdot 10^{-3}$	$0.7 \cdot 10^{-3}$	$2.6 \cdot 10^{-1}$	1.3	$9.6 \cdot 10^{-2}$	$2.3 \cdot 10^{-2}$
Range minimum	$2.0 \cdot 10^{-4}$	$0.4 \cdot 10^{-3}$	$1.9 \cdot 10^{-1}$	$6.0 \cdot 10^{-3}$	$1.5 \cdot 10^{-2}$	$4.9 \cdot 10^{-3}$
Range maximum	$6.7 \cdot 10^{-2}$	$7.8 \cdot 10^{-3}$	$4.9 \cdot 10^{-1}$	24	$2.6 \cdot 10^{-1}$	$6.7 \cdot 10^{-2}$
External dose rate						
Mean	$3.7 \cdot 10^{-2}$	$9.5 \cdot 10^{-3}$	0	$6.1 \cdot 10^{-3}$	$1.6 \cdot 10^{-2}$	$1.8 \cdot 10^{-5}$
Median	$3.4 \cdot 10^{-2}$	$8.0 \cdot 10^{-3}$	–	$5.5 \cdot 10^{-3}$	$2.6 \cdot 10^{-2}$	$1.8 \cdot 10^{-5}$
Standard deviation	$1.7 \cdot 10^{-2}$	$7.1 \cdot 10^{-3}$	–	$3.1 \cdot 10^{-3}$	$0.8 \cdot 10^{-2}$	$7.0 \cdot 10^{-6}$
Range minimum	$6.4 \cdot 10^{-3}$	$5.1 \cdot 10^{-3}$	–	$8.0 \cdot 10^{-4}$	$2.6 \cdot 10^{-2}$	$3.0 \cdot 10^{-6}$
Range maximum	$2.0 \cdot 10^{-1}$	$1.5 \cdot 10^{-2}$	–	$1.8 \cdot 10^{-2}$	$0.8 \cdot 10^{-2}$	$4.2 \cdot 10^{-5}$

* Estimation based on $^{210}\text{Pb} \rightarrow ^{210}\text{Po}$ tentatively equilibrium approximation.

** Estimation based on ^{238}U sediment activity concentration measurements and $^{238}\text{U} \rightarrow ^{226}\text{Ra}$ secular equilibrium approximation.

Table 2. Estimated weighted dose rates to above-sediment and rooted parts of submerged freshwater plants, attributed to anthropogenic radionuclides released by the INPP.

Parameters	Dose rate, $\mu\text{Gy/h}$			
	^{54}Mn	^{60}Co	^{90}Sr	^{137}Cs
Above-sediment part				
Internal dose rate				
Mean	$4.0 \cdot 10^{-5}$	$4.1 \cdot 10^{-4}$	$2.2 \cdot 10^{-3}$	$8.0 \cdot 10^{-4}$
Median	$2.3 \cdot 10^{-5}$	$3.0 \cdot 10^{-4}$	$1.9 \cdot 10^{-3}$	$5.0 \cdot 10^{-4}$
Standard deviation	$5.4 \cdot 10^{-5}$	$3.9 \cdot 10^{-4}$	$1.3 \cdot 10^{-3}$	$1.0 \cdot 10^{-3}$
Range minimum	$2.6 \cdot 10^{-7}$	$1.4 \cdot 10^{-5}$	$1.9 \cdot 10^{-4}$	$2.0 \cdot 10^{-5}$
Range maximum	$1.2 \cdot 10^{-3}$	$1.1 \cdot 10^{-2}$	$1.5 \cdot 10^{-2}$	$2.2 \cdot 10^{-2}$
External dose rate				
Mean	$4.2 \cdot 10^{-5}$	$2.8 \cdot 10^{-4}$	$3.3 \cdot 10^{-6}$	$3.2 \cdot 10^{-4}$
Median	$1.8 \cdot 10^{-6}$	$2.0 \cdot 10^{-4}$	$2.2 \cdot 10^{-6}$	$2.5 \cdot 10^{-4}$
Standard deviation	$8.8 \cdot 10^{-5}$	$2.7 \cdot 10^{-4}$	$3.6 \cdot 10^{-6}$	$2.4 \cdot 10^{-4}$
Range minimum	$7.6 \cdot 10^{-8}$	$7.5 \cdot 10^{-6}$	$6.6 \cdot 10^{-8}$	$9.3 \cdot 10^{-6}$
Range maximum	$3.1 \cdot 10^{-3}$	$4.8 \cdot 10^{-3}$	$6.8 \cdot 10^{-5}$	$3.2 \cdot 10^{-3}$
Rooted part				
Internal dose rate				
Mean	$3.9 \cdot 10^{-5}$	$4.4 \cdot 10^{-3}$	$2.3 \cdot 10^{-3}$	$8.4 \cdot 10^{-4}$
Median	$2.3 \cdot 10^{-5}$	$3.2 \cdot 10^{-3}$	$2.0 \cdot 10^{-3}$	$5.3 \cdot 10^{-4}$
Standard deviation	$5.6 \cdot 10^{-5}$	$4.1 \cdot 10^{-3}$	$1.4 \cdot 10^{-3}$	$1.1 \cdot 10^{-3}$
Range minimum	$2.7 \cdot 10^{-7}$	$1.8 \cdot 10^{-4}$	$2.4 \cdot 10^{-4}$	$1.3 \cdot 10^{-5}$
Range maximum	$1.3 \cdot 10^{-3}$	$7.9 \cdot 10^{-2}$	$1.5 \cdot 10^{-2}$	$3.3 \cdot 10^{-2}$
External dose rate				
Mean	$1.3 \cdot 10^{-3}$	$1.4 \cdot 10^{-2}$	$5.3 \cdot 10^{-3}$	$1.6 \cdot 10^{-2}$
Median	$5.3 \cdot 10^{-4}$	$9.9 \cdot 10^{-3}$	$4.0 \cdot 10^{-3}$	$1.3 \cdot 10^{-2}$
Standard deviation	$4.7 \cdot 10^{-3}$	$1.4 \cdot 10^{-2}$	$4.7 \cdot 10^{-3}$	$1.3 \cdot 10^{-2}$
Range minimum	$2.2 \cdot 10^{-6}$	$4.2 \cdot 10^{-4}$	$2.3 \cdot 10^{-4}$	$9.9 \cdot 10^{-4}$
Range maximum	$5.5 \cdot 10^{-1}$	$3.4 \cdot 10^{-1}$	$6.5 \cdot 10^{-2}$	$2.4 \cdot 10^{-1}$

activity data. Estimated dose rates to submerged hydrophytes from natural background and anthropogenic exposure are presented in Tables 1–3.

Comparison was made of LIETDOS-BIO simulated exposures to submerged hydrophytes due to natural

background radionuclides (^{40}K , ^{210}Pb , ^{210}Po , ^{232}Th , ^{226}Ra , ^{238}U) with that due to the main anthropogenic radionuclides discharged to Lake Drūkšiai from INPP (^{137}Cs , ^{90}Sr , ^{60}Co , ^{54}Mn) and low-level hypothetical near-surface radioactive waste disposal facility

Table 3. Estimated weighted dose rates to submerged hydrophytes attributed to anthropogenic radionuclides discharged by hypothetical near-surface low-level waste disposal.

Parameters	Dose rate, $\mu\text{Gy/h}$					
	^{14}C	^{36}Cl	^3H	^{129}I	^{99}Tc	^{237}Np
Internal dose rate						
Mean	$2.34 \cdot 10^{-5}$	$2.59 \cdot 10^{-5}$	$6.59 \cdot 10^{-7}$	$2.57 \cdot 10^{-7}$	$1.20 \cdot 10^{-3}$	$9.99 \cdot 10^{-3}$
Median	$2.31 \cdot 10^{-5}$	$2.56 \cdot 10^{-5}$	$6.54 \cdot 10^{-7}$	$2.54 \cdot 10^{-7}$	$1.19 \cdot 10^{-3}$	$9.87 \cdot 10^{-3}$
Standard deviation	$3.51 \cdot 10^{-6}$	$3.65 \cdot 10^{-6}$	$6.70 \cdot 10^{-8}$	$3.67 \cdot 10^{-8}$	$1.69 \cdot 10^{-4}$	$1.44 \cdot 10^{-3}$
Range minimum	$1.44 \cdot 10^{-5}$	$1.69 \cdot 10^{-5}$	$4.69 \cdot 10^{-7}$	$1.54 \cdot 10^{-7}$	$7.36 \cdot 10^{-4}$	$6.47 \cdot 10^{-3}$
Range maximum	$3.64 \cdot 10^{-5}$	$4.03 \cdot 10^{-5}$	$1.02 \cdot 10^{-6}$	$3.91 \cdot 10^{-7}$	$1.78 \cdot 10^{-3}$	$1.64 \cdot 10^{-2}$
External dose rate						
Mean	$6.08 \cdot 10^{-10}$	$3.70 \cdot 10^{-8}$	$3.00 \cdot 10^{-10}$	$4.17 \cdot 10^{-8}$	$4.20 \cdot 10^{-7}$	$9.08 \cdot 10^{-9}$
Median	$6.03 \cdot 10^{-10}$	$3.09 \cdot 10^{-8}$	$2.51 \cdot 10^{-10}$	$2.82 \cdot 10^{-8}$	$3.05 \cdot 10^{-7}$	$6.57 \cdot 10^{-9}$
Standard deviation	$8.14 \cdot 10^{-11}$	$1.94 \cdot 10^{-8}$	$1.50 \cdot 10^{-10}$	$4.09 \cdot 10^{-8}$	$3.61 \cdot 10^{-7}$	$8.06 \cdot 10^{-9}$
Range minimum	$3.46 \cdot 10^{-10}$	$1.42 \cdot 10^{-8}$	$1.12 \cdot 10^{-10}$	$1.49 \cdot 10^{-10}$	$5.78 \cdot 10^{-8}$	$8.17 \cdot 10^{-10}$
Range maximum	$1.06 \cdot 10^{-9}$	$1.37 \cdot 10^{-7}$	$1.09 \cdot 10^{-9}$	$2.61 \cdot 10^{-7}$	$2.66 \cdot 10^{-6}$	$6.58 \cdot 10^{-8}$

radionuclides discharged to the lake (^{36}Cl , ^{99}Tc , ^{14}C , ^{129}I , ^{237}Np). The predominant internal exposure dose rate, for the main natural background radionuclides (^{210}Po , ^{238}U , ^{226}Ra), is $1.24 \mu\text{Gy/h}$. The external exposure dose rate to above sediment part of submerged hydrophytes (due to ionizing radiation of all measured natural background radionuclides) was $0.069 \mu\text{Gy/h}$. Internal and external exposure simulations for submerged hydrophytes arising from anthropogenic radionuclides were several times lower.

The above data demonstrate that submerged hydrophytes exposures in Lake Drūkšiai are determined mainly by natural background radionuclides with predominance of ^{226}Ra ionizing radiation in the case of external exposure and internally incorporated α -emitters. ^{238}U is the major contributor in the case of internal exposure.

3.1. An international comparison of LIETDOS-BIO approaches to assess non-human biota radiation exposure

In response to international recommendations and requirements of existing legislation in some countries [3], a number of approaches have been developed to estimate the exposure of non-human biota to ionizing radiation. The LIETDOS-BIO code (as presented in Fig. 1) for non-human dose rate calculations has been validated and calibrated during the International Atomic Energy Agency EMRAS (Environmental Modelling for Radiation Safety) scientific programme [21]. The performance of the participating models was assessed by comparing reported results with established experimental reference values using a “Z-score”.

This scoring system, which is included in the International Organization for Standardization (ISO) guide-

lines as a standard method for laboratory assessment, was successfully used as a simple tool for comparison of different international approaches for the assessment of doses to non-human biota [22–25] (see the references for a description of the participant approaches). As the data considered in this study appear to be log-normally distributed, Z-scoring was performed on logarithmically transformed data for the purposes of comparison, using the following formula:

$$Z = \frac{\ln A_i - \ln \mu_g}{\ln \sigma_g}, \quad (6)$$

where A_i is the activity concentration of an organism, μ_g is the geometric mean, and σ_g is the geometric standard deviation. The results of this calculation procedure as a result of an international comparison of non-human biota exposure predictions are presented in Fig. 7. Because inclusion of ^3H and ^{14}C had some effect on the results of the intercomparison (due to higher data spread between models when considering these radionuclides), Fig. 7 shows a comparison of the relative effect of including or excluding these radionuclides. This kind of a simple method can be used to give each participant approach a normalized performance score for assessing bias. Care must be taken in interpreting the results, because the method is not designed to pass judgments on the goodness of any approach. With the above constraints in mind, the comparison of a particular approach with a group of other approaches is satisfactory if a relative bias is equal to or better than 25% (absolute value of Z is between 0 and 2). Z -score values between 2 and 3 indicate that the results are more different from the group of results considered in the intercomparison, and Z -score values ≥ 3 indicate that the measurements are highly differentiated. LIETDOS-BIO predictions

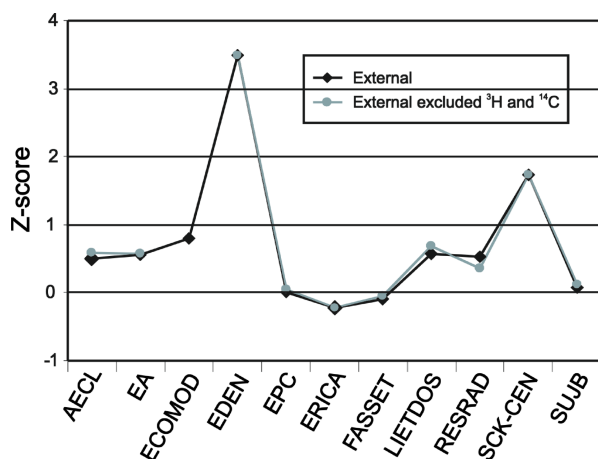

Fig. 7. Example of Z-scoring for an EMRAS external exposure DCC simulation with and without ^3H and ^{14}C : AECL code Atomic Energy Canada Limited, EA England and Wales Environment Agency “R&D 128”, ECOMOD Russia, EDEN France, EPC developed for the EC Inco-Copernicus Programme’s EPIC Project, ERICA developed under the 6th EC Framework, FASSET developed under the 5th EC Framework, LIETDOS Lithuania, RESRAD US DOE, SCK-CEN Belgium, SUJB Czech Republic [21].

were found to be comparable quite satisfactorily in this exercise with most Z-scores being typically between 0 and 2.

4. Conclusions

The LIETDOS-BIO code for non-human biota dose rate calculations was assessed during IAEA EMRAS BWG scientific program performance and modelled-to-measured activity concentration predictions were found to be acceptable with the absolute value of Z-score between 0 and 2 derived from the Z-score intercomparison.

The LIETDOS-BIO assessment of (a) submerged hydrophytes (used as a freshwater ecosystem biota exposure indicator) and (b) exposures due to anthropogenic Ignalina NPP and hypothetical near-surface low-level radioactive waste disposal radionuclides to be discharged to the cooling pond Lake Drūkšiai predicts substantially lower dose rates than the natural background exposure, ^{238}U and ^{226}Ra being the major contributors.

The preliminary data presented here make it possible to investigate Lake Drūkšiai from the viewpoint of non-human biota radiation protection in the case of nuclear energetics progression in Lithuania. A final decision on acceptability of this option awaits further review.

Acknowledgements

The authors express their sincere appreciation to the IAEA and Environmental Modelling for Radiation Safety Biota Working Group. The authors also wish to thank the participants of Lithuanian National Programs on “Thermal Power Generation and Environment” and “Atomic Energy and Environment” for their substantial contribution.

References

- [1] *Ethical Consideration in Protecting the Environment from the Effects of Ionizing Radiation*, TECHDOC-1270 (IAEA, Vienna, 2002).
- [2] *A Framework for Assessing the Impact of Ionizing Radiation on Non-human Species*, ICRP Publ. 91, Ann. 33/3 (ICRP, 2003).
- [3] *A Graded Approach for Evaluating Radiation Doses to Aquatic and Terrestrial Biota*, Technical Standard DOE-STD-1153-2002 (Washington D.C., 2002).
- [4] *Radiation Protection Recommendations as Applied to the Disposal of Long-lived Solid Radioactive Waste*, ICRP Publ. 81, Ann. ICRP 28(4) (1998).
- [5] *Joint Convention on the Safety of Spent Fuel Management and on the Safety of Radioactive Waste Management*, JC/RM3/02/Rev2 (2009).
- [6] *Environmental Protection: the Concept and Use of Reference Animals and Plants*, ICRP Publ. 108, Ann. ICRP 38(4–6) (2008).
- [7] *Environmental Risk from Ionising Contaminants: Assessment and Management (ERICA)*, Contract No FI6R-CT-2004-508847 (European Commission, Deliverable 6, 2006), www.ERICA-project.org.
- [8] *MCNPX User’s Manual Version 2.4.0*, Report LA-CP-02-408, ed. L.S. Waters (Los Alamos National Laboratory, 2002).
- [9] *Crystal-Ball User’s Manual Version 2*, ORACLE, www.oracle.com/crystalball/index.html.
- [10] V. Remeikis, A. Plukis, L. Juodis, A. Gudelis, D. Lukauskas, R. Druteikienė, G. Lujanienė, B. Lukšienė, R. Plukienė, and G. Duškesas, Study of the nuclide inventory of operational radioactive waste for the RBMK-1500 reactor, Nucl. Eng. Des. 239(4), 813–818 (2009).
- [11] J. Vives i Batlle, R.C. Wilson, S.J. Watts, S.R. Jones, P. McDonald, and S. Vives-Lynch, Dynamic model for the assessment of radiological exposure to marine biota, J. Environ. Radioact. 99, 1711–1730 (2008).
- [12] *Radionuclide Transformation Energy and Intensity of Emission*, ICRP Publ. 38, Ann. ICRP 11–13 (1983).
- [13] Ecosystem of water cooling reservoir of Ignalina Nuclear Power Station at the initial stage of its operation, in: *Thermal power generation and environment* (Academia Press, Vilnius, 1992) [in Russian].

- [14] *Atomic energy and environment*, Lithuanian National scientific programme, The Collection of Scientific Reports (Institute of Botany, Vilnius, 1997) [in Lithuanian].
- [15] J. Mažeika, *Radionuclides in geoenvironment of Lithuania* (Indra, Vilnius, 2002).
- [16] T. Nedveckaitė, *Radiation protection in Lithuania* (Kriventa, Vilnius, 2004) [in Lithuanian].
- [17] D. Marčiulionienė, R. Dušauskienė-Duž, E. Motiejūnienė, and R. Švobienė, *Radiochemical-ecological situation in Lake Drūkšiai – cooling pond of Ignalina NPP* (Academia, Vilnius, 1992) [in Russian].
- [18] C. Wirth, H. Koehler, and J. Burkhart, The suitability of transfer coefficients used for stochastic calculations in radioecology, *Health Phys.* **49**, 1165–1172 (1985).
- [19] T. Nedveckaitė, V. Filistovic, D. Marčiulionienė, D. Kiponas, V. Remeikis, and N.A. Beresford, Exposure of biota in the cooling pond of Ignalina NPP: hydrophytes, *J. Environ. Radioact.* **97**, 137–147 (2007).
- [20] *RESRAD-OFFSITE, a tool for evaluating radiation doses and risks*, www.evs.anl.gov/resrad/.
- [21] *EMRAS – Environmental Modelling for Radiation Safety*, www-ns.iaea.org/projects/emras/.
- [22] J. Vives i Batlle, M. Balonov, K. Beaugelin-Seiller, N.A. Beresford, J. Brown, J.J. Cheng, D. Coplestone, M. Doi, V. Filistovic, V. Golikov, J. Horyna, A. Hosseini, B.J. Howard, S.R. Jones, S. Kamboj, A. Kryshev, T. Nedveckaitė, G. Olyslaegers, G. Pröhl, T. Sazykina, A. Ulanovsky, S. Vives Lynch, T. Yankovich, and C. Yu, Inter-comparison of unweighted absorbed dose rates for non-human biota, *Radiat. Environ. Biophys.* **46**, 349–373 (2007).
- [23] N.A. Beresford, M. Balonov, K. Beaugelin-Seiller, J. Brown, D. Coplestone, J.L. Hingston, J. Horyna, A. Hosseini, B.J. Howard, S. Kamboj, T. Nedveckaitė, G. Olyslaegers, T. Sazykina, J. Vives i Batlle, T.L. Yankovich, and Ch. Yu, An international comparison of models and approaches for the estimation of the radiological exposure of non-human biota, *Appl. Radiat. Isotop.* **66**, 1745–1749 (2008).
- [24] N.A. Beresford, C.I. Barnett, J.E. Brown, J.J. Cheng, D. Coplestone, V. Filistovic, A. Hosseini, B.J. Howard, S.R. Jones, S. Kamboj, A. Kryshev, T. Nedveckaitė, G. Olyslaegers, R. Saxén, T. Sazykina, J. Vives i Batlle, S. Vives-Lynch, T. Yankovich, and C. Yu, Inter-comparison of models to estimate radionuclide activity concentrations in non-human biota, *Radiat. Environ. Biophys.* **47**, 491–514 (2008).
- [25] N.A. Beresford, C.L. Barnett, K. Beaugelin-Seiller, J.E. Brown, J.-J. Cheng, D. Coplestone, S. Gaschak, J.L. Hingston, J. Horyna, A. Hosseini, B.J. Howard, S. Kamboj, A. Kryshev, T. Nedveckaitė, G. Olyslaegers, T. Sazykina, J.T. Smith, D. Telleria, J. Vives i Batlle, T.L. Yankovich, R. Heling, M.D. Wood, and C. Yu, Findings and recommendations from an international comparison of models and approaches for the estimation of radiological exposure to non-human biota, *Radioprotection* **44**, 565–570 (2009).

LIETDOS-BIO METODAS BIOTOS APŠVITAI JONIZUOJANČIAJA SPINDULIUOTE VERTINTI

T. Nedveckaitė^a, V. Filistovič^a, D. Marčiulionienė^b, N. Prokopčik^a, A. Gudelis^a, R. Plukienė^a, V. Remeikis^a, J. Vives i Batlle^c

^a *Fizikos institutas, Vilnius, Lietuva*

^b *Gamtos tyrimų centro Botanikos institutas, Vilnius, Lietuva*

^c *Westlake Scientific Consulting Ltd., Jungtinė karalystė*

Santrauka

Iki pastarojo laikotarpio daug dėmesio buvo skirta žmogaus radiacinei saugai. Šiuo metu dėl branduolinės energetikos ciklo įmonių plėtros ir Europos Sąjungos, ir kitos nacionalinės bei tarptautinės organizacijos vis daugiau dėmesio skiria skirtingų ekosistemų (sausumos, gėlavandenės ir jūrinės) faunos ir floros (dažniausiai vadinamų biota) radiacinės saugos vertinimui. Vykdamas Tarptautinės atominės energetikos agentūros mokslinius projektus, įteisintas LIETDOS-BIO modelis ir kompiuterinė programa, kartu su tam tikslui sudaryta paprograme, kuri suderinta su MCNPX ir Crystall Ball programomis, leidžia įvertinti biotos apšvitą branduolinės energijos gamybos įrenginių ir radioaktyviųjų atliekų saugyklų bei kapinynų aplinkoje, taikant matematinės statistikos metodus neapibrėžtims įvertinti.

Taikant vietines sąlygas atitinkančius parametų dydžius, įvertinta Ignalinos AE aušinimo baseino Drūkšių ežero biotos apšvita, atsižvelgiant į galimą RESRAD-OFFSITE programa įvertintą radionuklidų sklaidą ir patekimo į ežerą galimybę iš 1,5 km nutolusio numatomo labai mažo aktyvumo (A klasės) radioaktyviųjų atliekų kapinyno. Gautieji preliminarūs duomenys rodo, kad biotos apšvita dėl gamtinės kilmės radionuklidų jonizuojančiosios spinduliuotės poveikio šiuo atveju yra žymiai didesnė, lyginant su dirbtinės kilmės radionuklidų sąlygota apšvita, bei neviršija šiuo metu Europos Sąjungoje rekomenduojamos didžiausios galimos 10 $\mu\text{Gy/h}$ dozės galios. Atliktas pradinis nagrinėjimas rodo kompleksinių tyrimų būtinumą siekiant nustatyti, ar Drūkšių ežeras yra naudotinas tolimesnei branduolinės energetikos plėtrai Lietuvoje.